

Instruction Manual For Advisor A75

Multirange

Digital Panel Meter (mV, V, mA and A input)

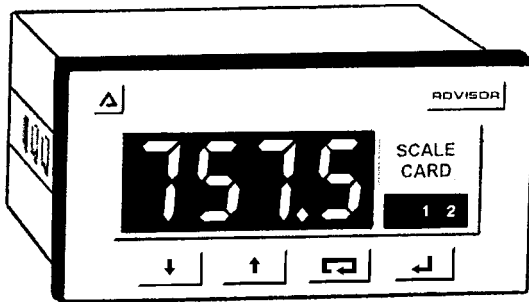

Features

- Wide Choice of Input Ranges, User Selectable (8 Voltage and 4 Current Inputs)
- 4 Digit Display
- Adjustable Brightness
- 24Vdc, 115Vac & 230Vac Models
- High Accuracy (0.05%)
- Reliable
- Maximum and Minimum Hold
- IP65 Front
- Easy Clean Membrane Buttons
- Button Disable Function (Anti-tamper)
- Password Protection
- Plain Language Programming Menus
- Optional Transducer Power Supply (User Selectable 5, 10, 12 or 15Vdc)
- Optional Transmitter Power Supply (24Vdc)
- Optional Dual Alarm Relays, Latching or Non-Latching, High or Low, Delays and Acknowledgement (Changeover 5A rated)
- Optional 4-20mA Analogue Output
- Optional Tare Function (Weighing Applications)

Contents

- 1) Unpacking
- 2) Safety and Warnings
- 3) Introduction
- 4) Electrical Specification
- 5) Dimensions
- 6) Installation
- 7) Electrical Connections
- 8) Setting Up
 - 8.1) General
 - 8.2) Button Functions – In Programming Mode
 - 8.3) General Programming Structure
 - 8.4) Main Programming Menu Flowchart
 - 8.5) Sub Menu Programming
 - 8.5.1) Square Root Extractor
 - 8.5.2) Display Resolution
 - 8.5.3) Decimal Point
 - 8.5.4) Max and Min Hold
 - 8.5.5) Display Units or Percentage
 - 8.5.6) Calibration – Internal or External Source
 - 8.5.7) Setting Internal References
 - 8.5.8) 4-20mA Analogue Output
 - 8.5.9) Front Panel Controls, Password and Pushbutton Disable (anti-tamper function)
 - 8.5.10) Alarm Setpoint Programming
 - 8.6) The Alarm Parameters
 - 8.6.1) Hysteresis
 - 8.6.2) Enable
 - 8.6.3) Setpoint 1(or Setpoint 2)
 - 8.6.4) High/Low
 - 8.6.5) Normally Energised
 - 8.6.6) Delay
 - 8.6.7) Silence
 - 8.6.8) Latch
 - 8.6.9) Access Setpoints
 - 8.7) Pushbutton Re-enable
 - 8.8) Transducer Supply Output
 - 8.9) Transmitter Supply
- 9) General Operation
 - 9.1) Button Functions – In Normal Display Mode
 - 9.1.1) Gaining Access to the Alarm Setpoints
 - 9.1.2) Resetting the Max/Min Register
 - 9.1.3) Display Brightness
 - 9.1.4) Unlatching Alarms and Alarm Silencing
 - 9.1.5) Tare Function
- 10) Troubleshooting
- 11) Typical Applications

1) Unpacking

The packaging for your Advisor A75 includes:

- 1) An Advisor A75 digital panel meter
- 2) A pair of panel mounting clips
- 3) A neoprene sealing gasket
- 4) Full set of connector blocks
- 5) A set of self-adhesive engineering unit labels
- 6) This instruction manual

Check your unit against the above parts list to make sure that nothing has been lost or damaged in transit. Keep the packing box as this will be useful if in the unlikely event you need to return the Advisor. If any parts are missing or damaged, please contact your supplier.

2) Safety and Warnings

The Advisor A75 has been designed and tested in accordance with the EU directive (73/23/EEC) for Low Voltage (LVD) apparatus and the EU Directive (89/336/EEC) for Electromagnetic Compatibility (EMC). Copies of the certificate of compliance and test reports are available on request.

It should be noted that the instrument is a panel mounted meter and after installation only the front panel is intended for general operator access. Installation must be completed by authorised and qualified personnel.

To ensure safe operation/installation the following warnings must be observed.



CAUTION:
Risk of electric shock



CAUTION:
Read instructions prior to installation and operation.

- Before installing the meter, ensure the marked rated voltage agrees with the actual power supply voltage.
- A safety earth must be connected to a conductive panel into which the meter will be installed. A safety earth must be connected with the AC mains supply to the instrument. (If applicable)
- Do not expose the rear of the meter to rain or condensing humidity.
- Do not use the meter in a flammable or explosive atmosphere.

3) Introduction

The Advisor A75 digital panel meter is one of a family of Advisor panel meters. The A75 has been designed specifically to display voltage or current process signals in engineering units. It is a microprocessor based instrument and consequently simple to use. The Advisor A75 has a user selectable input range. The power supply is selected at the time of ordering. Each Advisor has a display brightness control and max & min hold already included in the internal software.

There are also several other options that can be included with an Advisor including;

- Dual Alarms
- Analogue Output (4-20mA)
- Transducer Power Supply (user selectable, 5,10,12 or 15Vdc)
- Transmitter Power Supply (24Vdc @22mA)
- Internal Calibrator
- Root Extractor
- Tare Function (for weighing applications)

Advisors have been designed to be reliable in harsh environments. The front is rated with an ingress protection of IP65 and rear of IP20. The programming buttons on the front of the Advisors are sealed membrane type, thereby allowing the unit to be kept clean by hosing or wiping down.

4) Electrical Specification

Power Supply

10 to 35Vdc
99 to 132Vac 50/60Hz or
198 to 264Vac 50/60Hz

Power Consumption

4W Max.

Input Range (user selectable)

0-100mV, 0-200mV, 0-500mV, 0-1V, 0-2V, 0-5V, 1-5V,
0-10V, 0-20mA, 4-20mA, 0-50mA or 10-50mA

Input Impedance

Voltage input > 1 MOhms (>10 Mohms for 0-100mV and 0-200mV inputs)
Current input < 10 ohms

Isolation

500Vrms between input, power supply and any optional accessory outputs.

Accessories (factory fitted)

Alarms (Dual)

Single pole changeover relay contact, 250V @ 5A ac and 30V @ 5A dc.

Transmitter Power Supply

24Vdc @ 22mA short circuit protected

Transducer Supply Output

Selectable output 5,10,12 or 15Vdc @ 22mA, short circuit protected. Drift < 100ppm/°C

Analogue Output (4-20mA)

500 Ohms maximum load.

5) Dimensions

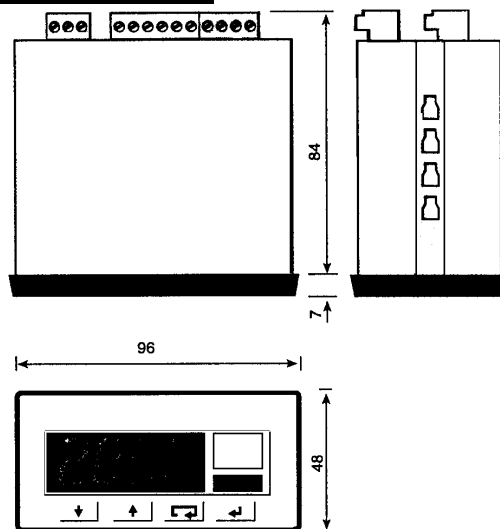

Recommended panel cut-out: (dimensions in mm)

DIN43 700. 92.0+0.8/-0.0 x 45+0.6/-0.0

To achieve an IP65 seal between the instrument and the panel
90.0+0.5/-0.0 x 43.5+0.5/-0.0

6) Installation

To install your Advisor, follow the installation procedure as outlined below.

- Insert the instrument into the panel opening from the front.

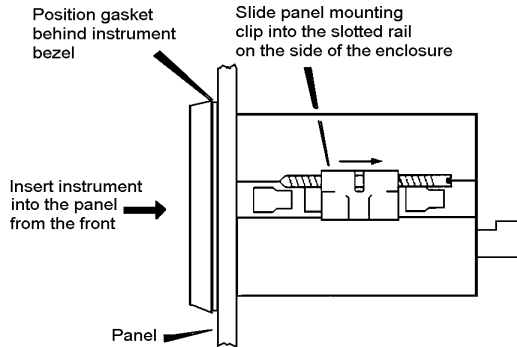

- Fix the two panel mounting clips to opposite sides of the instrument and tighten until the instrument is secure.
- Connect the panel wiring to the rear terminal blocks.

7) Electrical Connections

All connections to the instrument are made using high quality two part PCB connectors with screw clamp terminals (which accept cables between 0.5 and 1.5mm² in diameter).

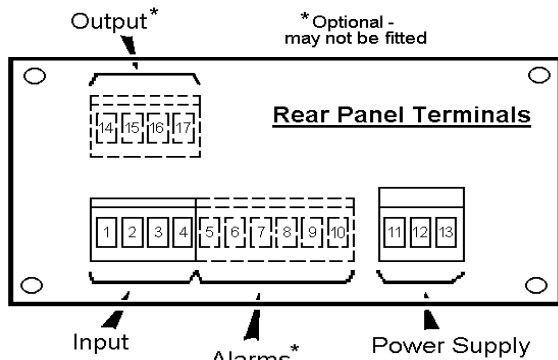

Power Supply Connections

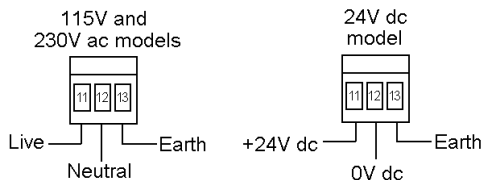

Signal Input and Optional Alarm Connections

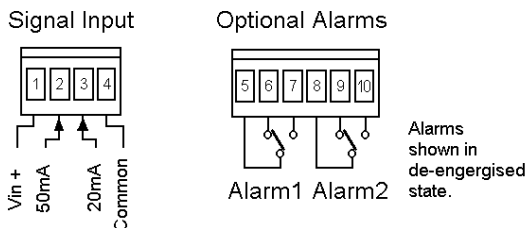

NOTE: Alarm terminals may carry up to 240Vac !

Optional Output Connections

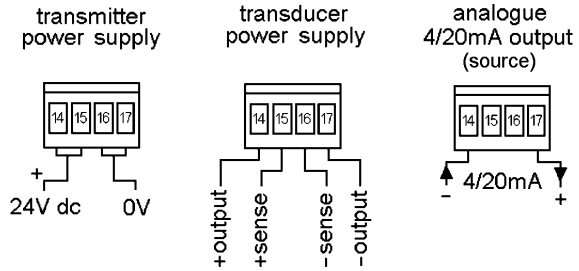

8) Setting Up

8.1 General

The Advisor panel meters are set up using the four front panel pushbuttons. Parameters are accessed using a plain language menu which can be protected by a user programmable password.

It is possible to disable the pushbuttons to stop any tampering by unauthorized personnel. If the anti-tamper pushbutton disable function has been switched on, you will need to regain "local" control by following the key press sequence as outlined in section 8.7

8.2 Button Functions – In Programming Mode

To enter Programming Mode, press the scroll and return buttons together.



When the instrument is supplied, the security access password is set to "0000". If this password has not been changed, then the operator is given immediate access to the programming mode. If the password has been changed, then the operator will need to enter the new password before being able to access programming mode. If the password has been forgotten – see section 8.5.9)

In Programming Mode, the pushbuttons have the following functions;

- Decreases a setting/variable or moves to the previous menu option. This button is referred to as the "down button"
- Increases a setting/variable or moves to the next menu option. This button is referred to as the "up button"
- Select a menu option or "scroll into" next menu option. This button is referred to as the "scroll button".
- Confirm variable selection or return to previous menu option or exit programming mode. This button is referred to as the "return button".

8.3) General Programming Structure

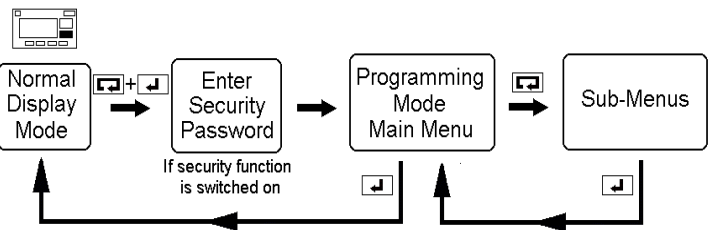

The above flow chart gives a general overview of the programming structure for an Advisor. The key point to remember is that if you ever get lost or unsure of what function you are programming, keep pressing the return button and eventually you will get back to the Normal Display Mode.

8.4) Main Programming Menu Flowchart

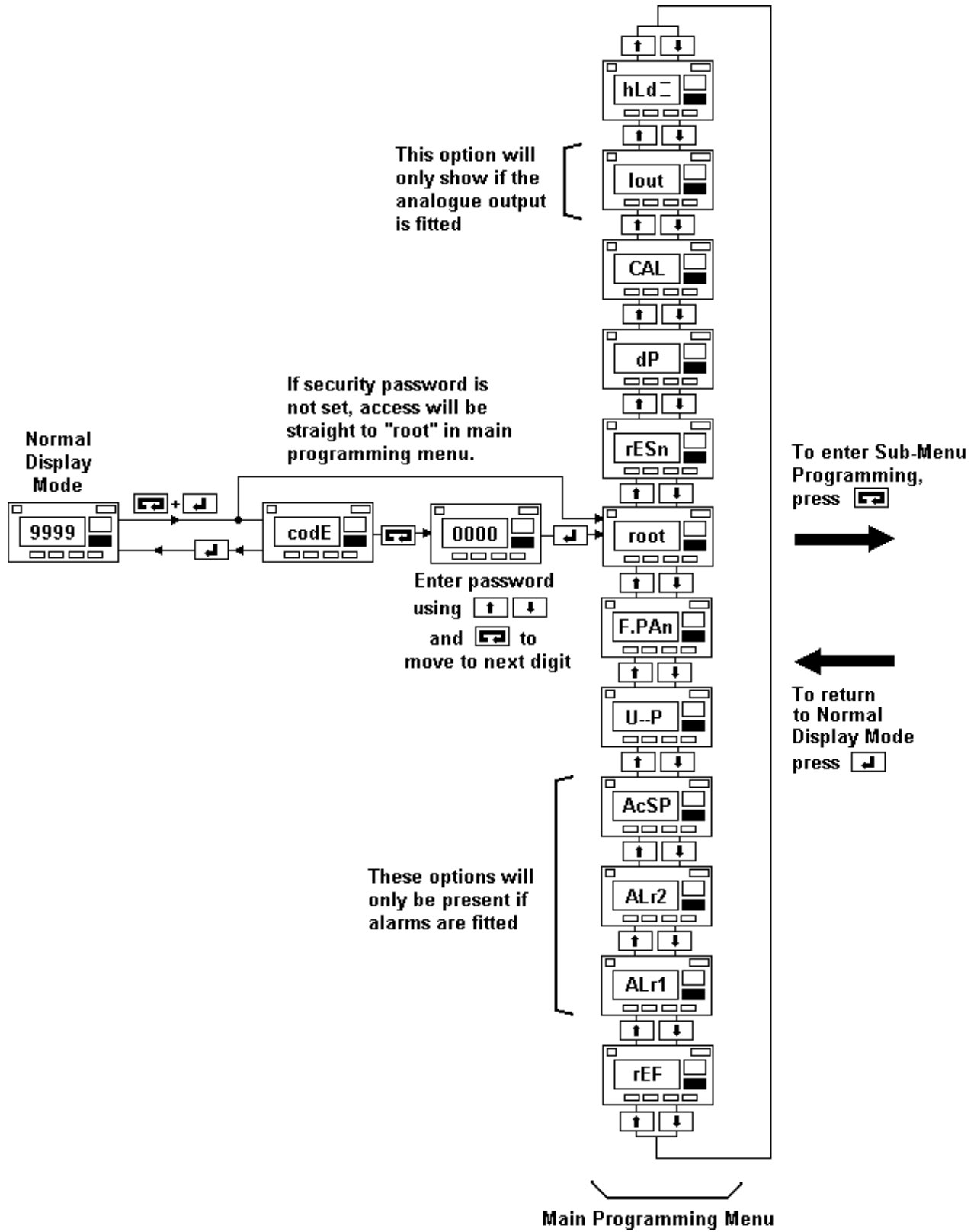

8.5) Sub Menu Programming

Sub-Menu Programming allows the entry of variables and enabling/disabling of various functions.

8.5.1) "root" – Square Root Extractor. This parameter enables or disables the square root linearising function. When enabled, an exponential input signal is displayed in linearised form. (For example, a differential flowmeter may have an exponential output).

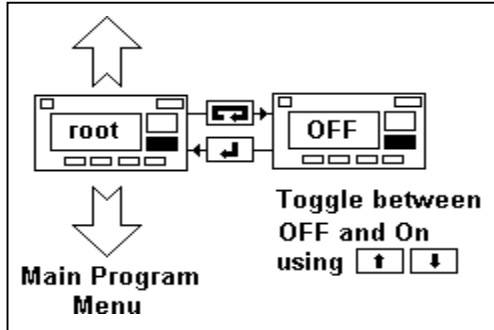

8.5.2) "rESn" - Display Resolution. This parameter sets the resolution of the least significant display digit. It may be set to 1,2,5 or 10. This can be useful if the source signal is noisy. For example, setting a display resolution to 5 would mean the display only increases or decreases in steps of 5 digits, thus "smoothing" the display.

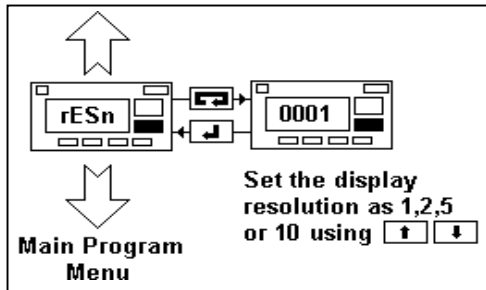

8.5.3) "dP" - Decimal Point. This function allows the

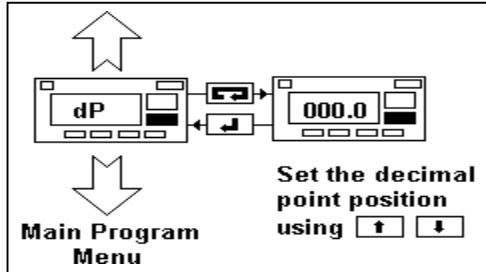

position of the decimal point to be selected.

8.5.4) – "hLd" Max and Min Hold. Whether this function is "On" or "OFF", the maximum and minimum values displayed are being stored in the max/min hold register. In Normal Display Mode, with this parameter "On", the max and min values stored can displayed (by pressing the up and down buttons) and reset (by pressing the up and down buttons together). The maximum and minimum values will be lost on power failure.

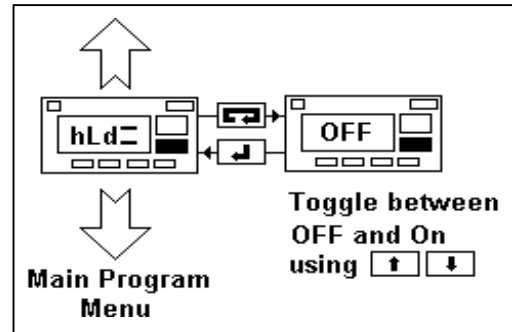

8.5.5) "U--P" - Display Units or Percentage. In Normal Display Mode, the scroll button can be programmed to give one of two readings, either the actual signal input in its own units or the percentage of span reading. The "units" function will be incorrect if the internal references have not been set. (See section 8.5.7)

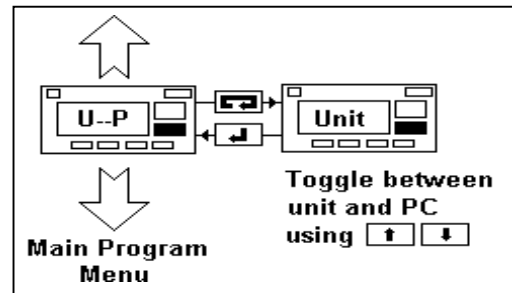

8.5.6) "CAL" - Calibration - internal or external

source. The "int" (internal) calibration function allows a quick calibration. The display range ("zero" and "span") can be set within this menu option. The accuracy of this method is dependent on the accuracy of the internal references set under the "rEF" menu. (See section 8.5.7). The preferred method of calibration is to use an accurate, traceable external source. To calibrate using this method, select "uSEr" followed by "ZEro" and apply a zero signal to the input terminals. Enter the reading desired for this input and sample the signal by pressing the return button. Next, select "SPAn", set the appropriate input signal and enter the corresponding reading. Increase the signal source to the span (upper) value and sample the input by pressing the return button.

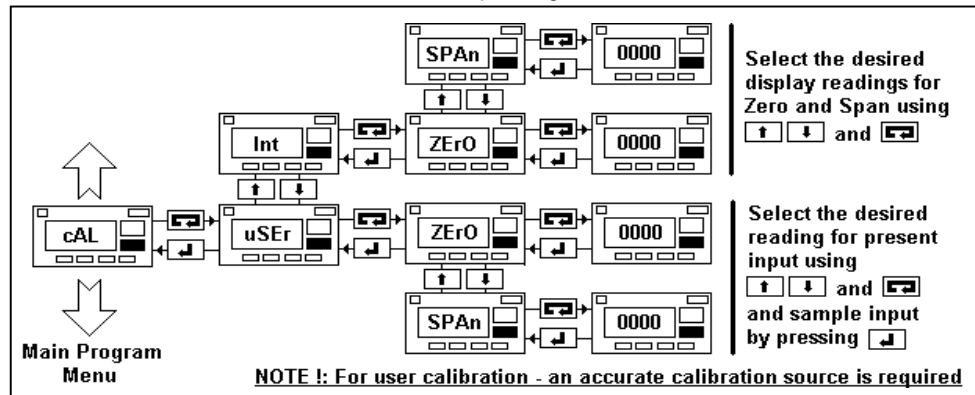

8.5.7) "rEF" – Setting Internal References. Do NOT enter this program parameter unless you have an accurate and traceable signal source. The internal references are used by the meter to calculate readings for the internal calibrator ("cAL"), the units/percentage function ("U-P") and the analogue output option. The internal references are protected against accidental erasure or alteration by the operator having to enter the access word "SurE". The A75 can accept any one of twelve different input signal ranges. The input range is selected under the sub-menu option "rAng". See table 1 below for the choice of inputs. After selecting the input range, using an accurate signal source sample signals associated with the "zero" and "span". For example if the signal input range was 1-5V, 1V would need to be sampled for the "zero" and 5V would need to be sampled for the "span". The 4-20mA analogue output (if fitted) can be adjusted (to a minimum of 3.8mA and a maximum of 22mA) using the up or down buttons within the "SEt" options.

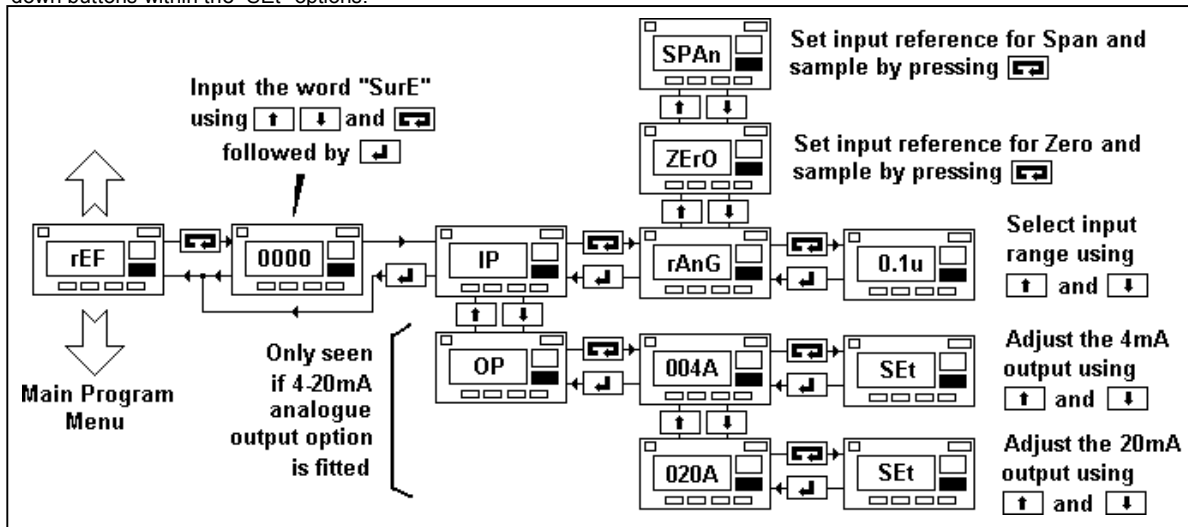

Please note to ensure maximum accuracy, whenever the input signal range of the indicator is changed as outlined in section 8.5.7, (for example, change the input from 0-10V to 4-20mA), the display should also be re-calibrated as outlined in section 8.5.6.

Table 1: Choice of input range and the corresponding "rAng" settings

Input Range	"rAng" Setting
0-100mV	0.1u
0-200mV	0.2u
0-500mV	0.5u
0-1V	1u
0-2V	2u
0-5V	5u
0-10V	10u
0-20mA	0.02A
0-50mA	0.05A
1-5V	1-5u
4-20mA	4-20
10-50mA	10.50

8.5.8) "Iout" – 4-20mA Analogue Output. (If fitted)

This parameter allows the 4-20mA analogue output to be programmed to correspond to any part of the display range. For example, the display range could be 0-500 Litres, and the 4-20mA analogue output could be from 100-150 Litres. To set the actual mA output refer to section 8.5.7.

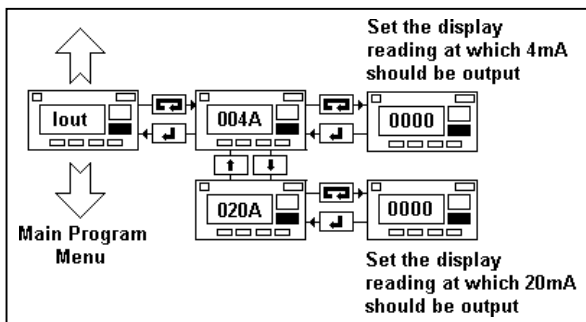

8.5.9) "F.Pan" - Front Panel Controls, Password and Pushbutton Disable (anti-tamper function).

The front panel controls ("F.PAn" parameters) allow a security access password to be set or altered and allow the pushbuttons to be enabled or disabled. If the "bttN" parameter is "on", then the pushbuttons will function normally, if the "bttN" parameter is set to "off" then the pushbuttons will be disabled (to re-enable see section 8.7). The security password set in "CodE" will be the password required for anyone to gain access to the Programming Mode. If password controlled access is not needed, the code should be set to "0000" (four zeroes).

If a password is forgotten, then the emergency access code "FPac" ("Forgotten Panel Access Code") will provide access.

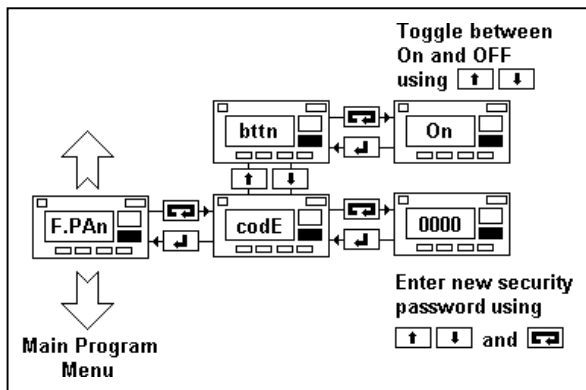

8.5.10) "ALr1" & "ALr2" –Alarm Setpoint Programming (If Fitted).

Section 8.6) outlines the alarm parameters that can be set.

8.6) The Alarm Parameters.

Alarms (1 & 2) have the same set-up parameters, but operate independently of each other. Each can be set as a high or low alarm.

8.6.4) "hILO" - High/Low. Each alarm can be set as either active high or active low.

8.6.5) "nE" - Normally Energised. This parameter determines the state of the changeover relay. If "nE" is "on" then the alarm relay is normally energised i.e. an alarm state will cause the relay to be de-energised. If the alarm is normally energised, this will also produce a "failsafe" condition should there be a power failure.

8.6.6) "dELA" - Delay. This function can be programmed to delay an alarm by up to 3600 seconds. If set to "0000" then the alarm delay is off.

8.6.7) "SIL" - Silence. This function allows the relay outputs to be de-activated (or silenced) for up to 3600 seconds. Hence, an alarm sounder connected to the output relays could be momentarily "silenced" by the operator pressing the scroll button. If the input signal is still in the alarm range after the silence time had elapsed, the alarm is automatically re-activated.

8.6.8) "Ltch" - Latch. This function allows the alarms to be latched on. If the input signal causes the alarm to trip and this function is "on", the relay output(s) will be held in the alarm state even if the input signal falls back into the normal operating range. In Normal Display Mode, a latched alarm is acknowledged (released) by pressing the scroll button.

8.6.9) "AcSP" - Access Setpoints. This option allows an operator direct access to the alarm setpoints without having to go through all the other programming menus. When this function has been enabled, pressing the scroll and up button together will give the operator access to the setpoints. Access can be limited by setting a password under the "Access Code" ("Ac.cd") parameter. The same password can be used gain access to both the alarms and main programming menus.

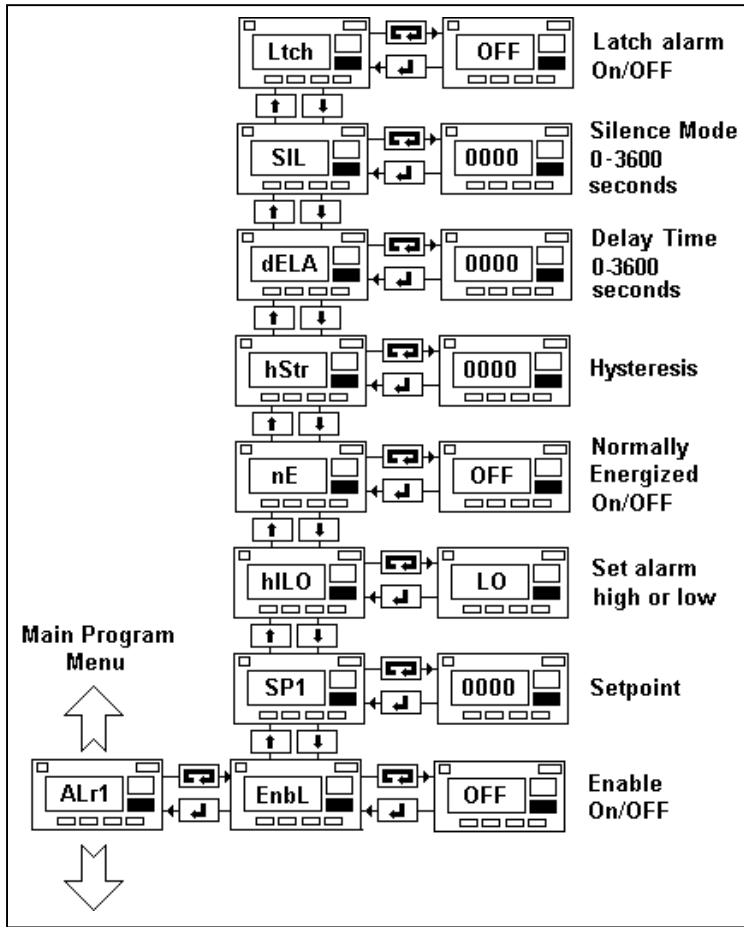

8.6.1) "hStr" - Hysteresis. On an Advisor, hysteresis is set in engineering units not percentage and can be set to any value. Hysteresis can be used to stop alarm "chatter" as the diagram shows.

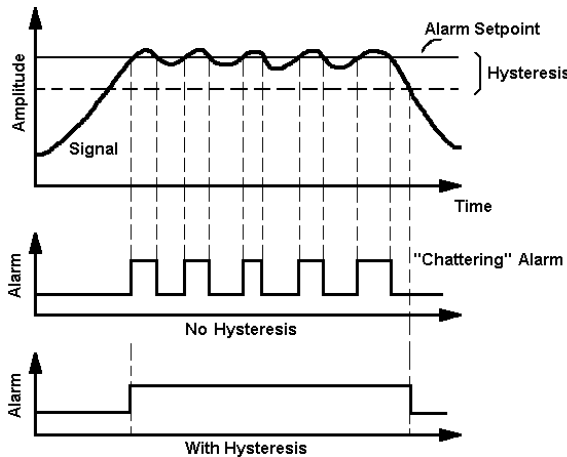

8.6.2) "EnbL" - Enable. This parameter enables an alarm to be easily switched on or off without having to change all the other alarm parameters. **NOTE: If the alarms are not enabled, the alarm relays will stay in the position determined by the "nE" (normally energised) parameter.**

8.6.3) "SP1" - Setpoint 1. (or setpoint 2). This is the alarm setpoint value and is entered in the same units as the display.

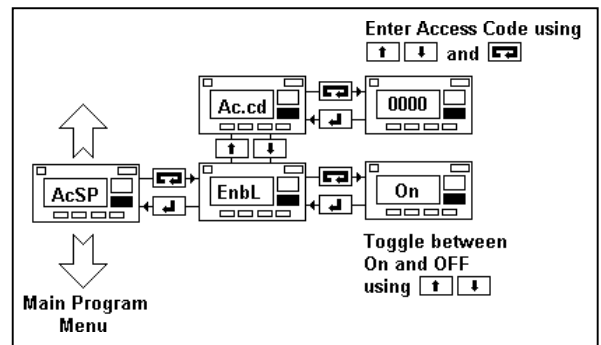

8.7) Pushbutton Re-enable

The pushbutton disable function or anti-tamper function (see section 8.5.9) allows the pushbuttons to be disabled - ideal if the Advisor could be open to tampering from unauthorized personnel. Once this function has been switched on, the only way to regain control of the pushbuttons is to push the buttons in the following sequence.

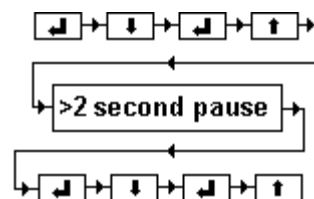

Once this sequence has been followed, the display will briefly show "good" and the buttons will be re-enabled.

8.8) Transducer Supply Output (if fitted).

To change a transducer supply output voltage, internal jumper links must be adjusted. **Switch off the power and disconnect all the connectors.** Remove the four retaining screws at the back of the instrument and carefully slide the electronic board sets out of the case until the top sub-board with the jumper links is revealed (as per diagram).

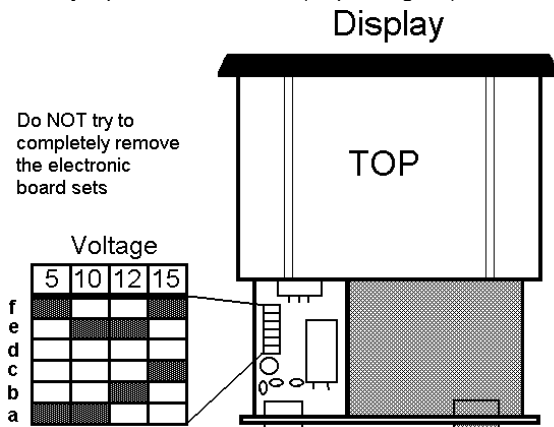

NOTE: The electronic circuit board sets are not designed to be completely removed from the case !! Position the links in the appropriate places (e.g. 12Vdc supply requires links to be in position b and e) and carefully re-assemble. The transducer supply is short circuit protected.

The transducer supply is a 4 wire output – this eliminates cable resistance. The two sense terminals (15 and 16) **must be** connected to either the sensor (best practice) or the transducer supply outputs i.e. link terminals 14 to 15 and 16 to 17.

8.9) Transmitter Supply Output (if fitted)

The transmitter supply output voltage is 24Vdc and is not adjustable. It supplies up to 22mA (short circuit protected) – ideal for loop-powered transmitters.

9) General Operation

9.1 Button Functions – In Normal Display Mode

 Pressing this button causes the display to show one of the following variables. Listed in order of priority.

- The minimum value held in the max/min hold register (if enabled)
- The display at which 4mA is re-transmitted on the analogue output (if fitted)
- The display reading corresponding to the lower end of the calibrated range.

After 5 seconds of pressing and holding this button, the display brightness will be reduced.

 Pressing this button causes the display to show one of the following variables. Listed in order of priority.

- The maximum value held in the max/min hold register (if enabled)
- The display at which 20mA is re-transmitted on the analogue output (if fitted)
- The display corresponding to the upper end of the calibrated input range.

After 5 seconds of pressing and holding this button, the display brightness will be increased.

 Pressing this button has several effects depending on what parameters have been programmed. It can

be programmed to display the input signal in actual units or as a percentage of the input range. It can also be used to silence alarm outputs, acknowledge latched alarms and to activate the tare function.

 This button has no effect during Normal Display Mode.

Certain combinations of simultaneous button presses also cause the meter to perform other functions.

9.1.1) Gaining access to the alarm setpoints.

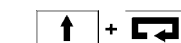
 It may be necessary for an operator to regularly change alarm setpoints without having to go through all the programming menus. To access the alarm setpoints (if the function has been switched on in program mode – see section 8.6.9) the up and scroll buttons should be pressed simultaneously. The operator will then be able to access setpoints (SP1 and SP2) by pressing the up button. New setpoints can then be entered with the up, down and scroll buttons followed by the return button.

A security access code can be programmed (see section 8.6.9) to verify authorized access to the setpoints. If this is the case, the operator must enter the security access code using the up, down and scroll buttons, followed by the return button.

9.1.2) Resetting the Max/Min Register.

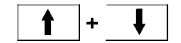
 By pressing the up and down buttons simultaneously, the max/min hold register is reset to store the present display reading.

9.1.3) Display brightness

It is possible to adjust the brightness of an Advisor at any time during Normal Display Mode.

To increase the display brightness, press and hold the up button. After 5 seconds, all the segments on the display will light up and the brightness will steadily increase to its maximum. Release the button when the desired brightness is reached. The same method is used to lower the brightness, by using the down button. The display brightness is “remembered” if there is a power failure.

9.1.4) Unlatching alarms and alarm silencing (if fitted)

A latched alarm is unlatched by pressing the scroll button. (To set a latch on an alarm – see section 8.6.8). The alarm changes state and the alarm LED annunciator is extinguished. An alarm is also silenced (or acknowledged) with the same button press (to enable alarm silencing see section 8.6.7). With a silenced alarm, the contacts will change state but the alarm LED annunciator will remain lit if the input signal is still within the alarm band.

9.1.5) Tare Function (if fitted)

The tare function is designed primarily for use in weighing applications and is a factory fitted accessory. A tare function allows the instrument display to be zeroed at any stage so that any further change in input signal can easily be measured. For example, if the Advisor was showing the weight of a container as 25kg and an operator wanted to add 18kg of fluid, the display could be tared and the operator would easily see when 18kg of fluid had been added. Without the tare function, the operator would have to calculate the combined weight.

The tare is initiated by pressing and holding the scroll button for 4 seconds, the word “tArE” is then briefly displayed. The asterisk LED annunciator will also light up to show that the display is tared. Brief pressing of the scroll button allows the operator to toggle between the tared (net) display and the untared (gross) display. The asterisk LED annunciator switches on and off accordingly. The display can be re-tared again at any time by pressing and holding the scroll button for

4 seconds. The tare value is stored even if there is a power failure.

10) - Troubleshooting

There is no display. Check all the connections are correctly made and check the power supply for the correct rating.

I have changed the input type, and no longer have a sensible reading. Make sure you have changed over the input connectors for example, changing an input from 4-20mA to 0-10V will require the input to be changed from terminals 3&4 to 1&4.

The display is not very bright/too bright. Adjust the brightness by pressing and holding the up or down button. (Section 9.1.3)

Display doesn't seem to be responding to a change of input signal. Check the input signal. It may also be possible that someone has accidentally re-calibrated the unit to display the same value over the full input range – check the span and zero settings in the “cAL” parameters (Section 8.5.6) – if necessary re-calibrate with the “Int” (internal) settings. Alternatively, the internal references may have been accidentally reset – re-program them. (Section 8.5.7)

None of the pushbuttons seem to be working. It may be that the pushbuttons have been disabled (i.e. anti-tamper function has been switched on). Enter the button re-enable sequence. (Section 8.7)

The display is too “jumpy”. Check the signal source, it may be noisy. If the signal source cannot be “damped” down, change the resolution of the Advisor. (Section 8.5.2)

I've forgotten my password – how do I get access ? Enter “FPAc” (the emergency code – mnemonic “Forgotten Panel Access Code”) and re-enter a new password in “F.PAn” menu option. (Section 8.5.9)

The alarms are on when they should be off and vice versa. Check the high and low alarm settings (Section 8.6.4) and/or check you have the normally energized (“nE”) parameter correctly programmed (Section 8.6.5)

The analogue output current doesn't seem to be correct. The analogue output can be adjusted. (Section 8.5.8)

The transducer supply output is higher than expected. Remember, the transducer supply output is a 4 wire output i.e. 2 supply lines and 2 sense lines. The sense lines must be connected either directly to the sensor or to the supply outputs otherwise the Advisor will “hunt” for a sensor and the output voltage will seem to be excessive. (See section 8.8)

11) Typical Applications

A Position Sensor (0-10V input signal)

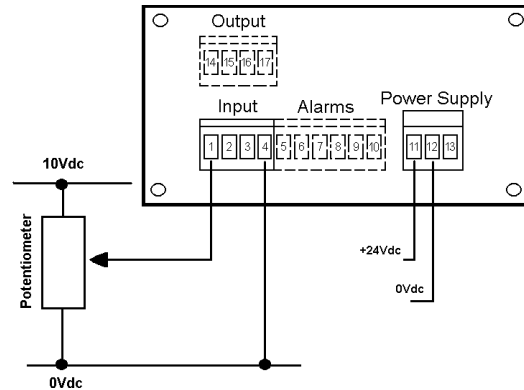

Tank Level Display (4/20mA Active Sensor)

Transmitter has its own power supply

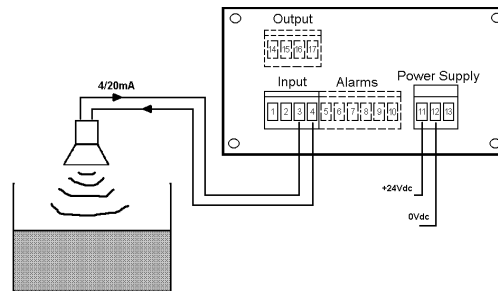

Temperature Display (4/20mA Passive – Loop-powered Transmitter)

24Vdc transmitter power supply option fitted

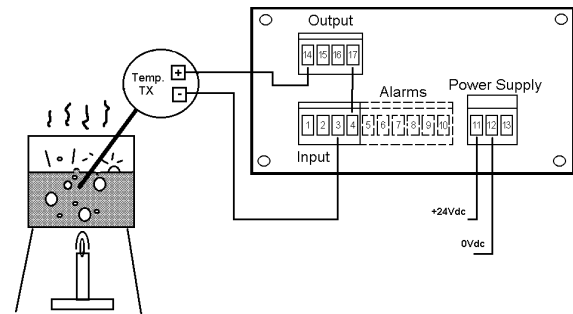

Weight Display (15Vdc Transducer supply output, 0-100mV input range)

Transducer power supply fitted.

